



# R315 TO-39



## 1. SCOPE

This specification is applied to a SAW resonator designed for the stabilization of transmitters such as garage door openers and security transmitters.

## 2. ELECTRICAL SPECIFICATION

### 2.1 Maximum Rating

DC Voltage VDC	10V
AC Voltage Vpp	10V 50Hz/ 60Hz
Operation temperature	-40 °C to + 85 °C
Storage temperature	-45 °C to + 85°C
Max Input Power	10 dBm

### 2.2 Electronic Characteristics

Item	Unites	Minimum	Typical	Maximum	
Center Frequency	MHz	314.925	315.000	315.075	
Insertion Loss	dB		1.5	2.2	
Quality Factor Unload Q		8000	12800		
50Ω Loaded Q		850	1500		
Temperature	Turnover Temperature	°C	10	25	40
Stability	Freq.temp.Coefficient	ppm/°C <sup>2</sup>		0.037	
Frequency Aging		ppm/Yr		≤10	
DC. Insulation Resistance	MΩ	1.0			
RF Equivalent RLC Model	Motional Resistance R1	Ω	17	26	
	Motional Inductance L1	μH	109.28		
	Motional Capacitance C1	fF	2.3357		
Transducer Static Capacitance	pF		2.7		





# R315 TO-39



## 3. TEST CIRCUIT

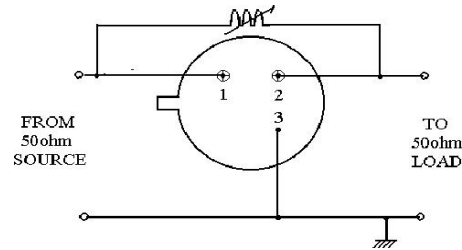

R315 TO39 3Pin

## 4. DIMENSION

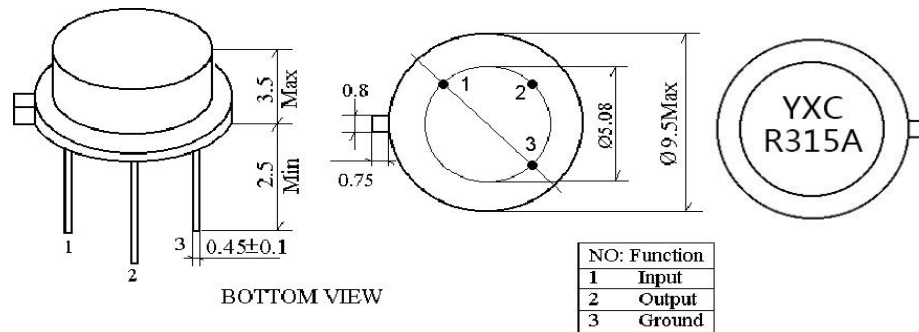

R315 TO39 3Pin

## 5. ENVIRONMENTAL CHARACTERISTICS

### 5-1 High temperature exposure

Subject the device to +85°C for 16 hours. Then release the resonator into the room conditions for 24 hours prior to the measurement. It shall fulfill the specifications in 2.2.

### 5-2 Low temperature exposure

Subject the device to -40°C for 16 hours. Then release the device into the room conditions for 24 hours prior to the measurement. It shall fulfill the specifications in 2.2.

### 5-3 Temperature cycling

Subject the device to a low temperature of -40°C for 30 minutes. Following by a high temperature of +85°C for 30 Minutes. Then release the device into the room conditions for 24 hours prior to the measurement. It shall meet the specifications in 2.2.

### 5-4 Resistance to solder heat

Dip the device terminals no closer than 1.5mm into the solder bath at 260°C ±10°C for 10 ±1 sec. Then release the device into the room conditions for 4 hours. The device shall meet the specifications in 2.2.



# R315 TO-39



## 5-5 Solderability

Subject the device terminals into the solder bath at  $245^{\circ}\text{C} \pm 5^{\circ}\text{C}$  for 5s, More than 95% area of the terminals must be covered with new solder. It shall meet the specifications in 2.2.

## 5-6 Mechanical shock

Drop the device randomly onto the concrete floor from the height of 1m 3 times. the device shall fulfill the specifications in 2.2.

## 5-7 Vibration

Subject the device to the vibration for 1 hour each in x, y and z axes with the the amplitude of 1.5 mm at 10 to 55Hz. The device shall fulfill the specifications in 2.2.

## 6. REMARK

### 6.1 Static voltage

Static voltage between signal load & ground may cause deterioration & destruction of the component. Please avoid static voltage.

### 6.2 Ultrasonic cleaning

Ultrasonic vibration may cause deterioration & destruction of the component. Please avoid ultrasonic cleaning

### 6.3 Soldering

Only leads of component may be soldered. Please avoid soldering another part of component.

## 7. TYPICAL APPLICATION CIRCUITS

### Typical low-power Transmitter Application

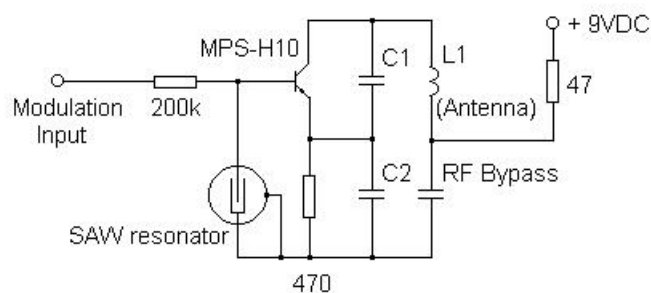

### Typical Local Oscillator Application

